



# Flanged Specialty Unit Installation

LINCOLN WOOD PRODUCTS, INC.

**These installation instructions are to be used when installing the following Lincoln Windows: Aluminum Clad Radius & Geometric Direct Set and Sash Set Units.**

This instruction provides the minimum recommended procedures to correctly prepare the rough opening, install a flanged specialty unit and apply flashing within a residential or light commercial structure that has the weather resistant barrier applied. Local climate may dictate additional flashing at the discretion of the installer. These instructions are minimal recommendations only and do not supersede local building codes

**CAUTION:** If installing window into an older home, lead-based paint may be present. To minimize the exposure to possible lead-based paint during the removal of the existing windows, please consult [www.epa.gov/lead](http://www.epa.gov/lead) for recommendations.

Please follow recommended local guidelines to properly recycle and/or dispose of all product packaging and construction/renovation waste.

Proper installation and maintenance of Lincoln windows is essential to proper window performance. Failure to follow these installation and flashing guidelines may void Lincoln's Limited Warranty. Lincoln recommends installation of its product by experienced contractor personnel. If you have questions regarding window installation, contact your Lincoln dealer, an experienced contractor or contact Lincoln at (800) 967-2461.

## TOOLS/HARDWARE REQUIRED:

- Safety Glasses
- Hearing Protection
- Tape Measure
- Level
- Putty Knife
- Sealant & Caulk Gun
- 1/4" Shims
- Flashing Tape
- Backer Rod
- Insulation/Foam Sealant
- Hammer
- 1" Stainless or Galvanized Nails

### Preparing the Rough Opening (R.O.)

**Structural Support & Bracing:** Additional structural support for specialty shape windows will need to be added to the rectangular opening in the form of bracing and shimming, to prevent any vertical load from being transferred to the window. Additional support also provides more anchor points for fasteners to securely hold the window square, plumb and level (fig.1).

**CLEARANCE:** Lincoln Wood Products Inc. published rough openings allow for a 1/4" of clearance on all sides of the unit for insulation purposes. Use of 1/4" shims on a level sill to provide proper spacing is recommended prior to setting any unit.

**MEASURING FOR SQUARE:** Take measurements from bottom left corner to top right corner and bottom right corner to top left corner and compare. If measurements are equal the R.O. is square. If measurements are not equal, R.O. is out of square and it is then the responsibility of the installer to remedy this problem (fig.1).

**CHECKING FOR PLUMB:** Place a level on both sides of the R.O. making sure the vertical measurement of each side is true. If R.O. is not plumb, it is then the responsibility of the installer to remedy this problem (fig.1).

**CHECKING LEVEL:** Place a level on the sill of the R.O. making sure the horizontal measurement on the sill is level. If opening is not level, the use of shims may be used to level the sill (fig.1).

**NOTE:** Unit must be installed square, plumb and level or warranty may be void

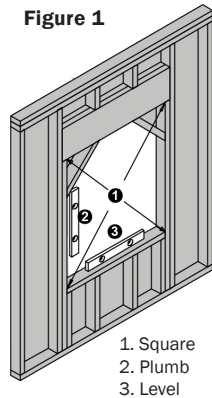

Figure 1

1. Square
2. Plumb
3. Level

### Preparing the Weather Resistant Barrier

With a marker, draw a series of lines to be cut. Start from the top left of the spring line and continue horizontally to the top right spring line. From the bottom left corner of the R.O. draw a line up approximately 45°. Repeat for opposite side so the two lines intersect. From the intersection draw a line up to the first horizontal line drawn. This will allow installer to wrap the weather resistant barrier to the inside.

Using a utility knife cut the lines in the barrier starting at the top of the vertical line and work down towards either the left or right corner of the R.O. Next start at the left or right spring line and cut across horizontally.

Lastly cut barrier flush with the top of the R.O. along the arch. This will allow the installer to remove the curved piece of barrier and fold the side and bottom flaps into the interior side of the rough opening. Using staples every 12" to 16" fasten the flaps to the interior and trim excess (fig.3).

Per ASTM standards Lincoln Wood Products, Inc. recommends a minimum of 9" wide flexible flashing. For that reason, measure 9" up and 9" over from either the left or right of the spring line and mark. A scrap piece of flashing 9" x 9" may be used to simplify this step. Once marked, cut the weather barrier diagonally from the spring line to the mark made previously (fig.2). This should give you a 45° cut. Then make a cut upwards vertically from the top of the 45° cut so that the weather barrier can be folded up and temporarily taped at least 9" from the top of the R.O. (fig.3).

Additional cutting patterns are illustrated in this installation. If a certain pattern is not shown, please contact Lincoln at (800) 967-2461.

**SILL FLASHING:** The flashing can be flexible or adhesive back flexible. All flashing must be at least 9" wide & meet **(ASTM D-779; water resistance of at least 24+ hours)**.

Apply a piece of flashing ① that is 18" longer than the rough opening. Apply sill flashing level with top edge of R.O. allowing 9" of flashing to extend to each side of R.O. (fig. 4).

If using non adhesive flashing fasten the top and sides of the sill flashing with staples located 12" to 16" apart, locate them where they will be covered by the nail flange of the window.

Apply a piece of flashing ② that is cut 12" longer than the rough opening. Apply the flashing so it is flush with the interior edge of the rough sill and notched at the corners to allow the flashing to extend 6" up the jambs (fig. 4).

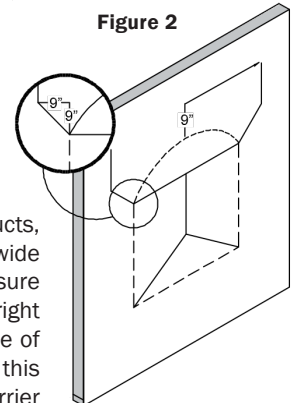

Figure 2

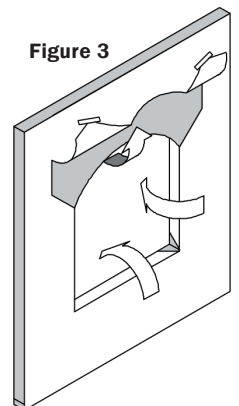

Figure 3

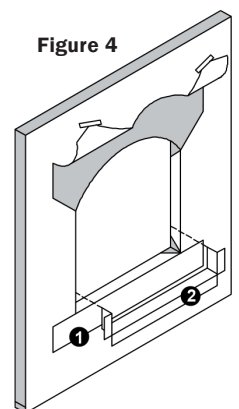
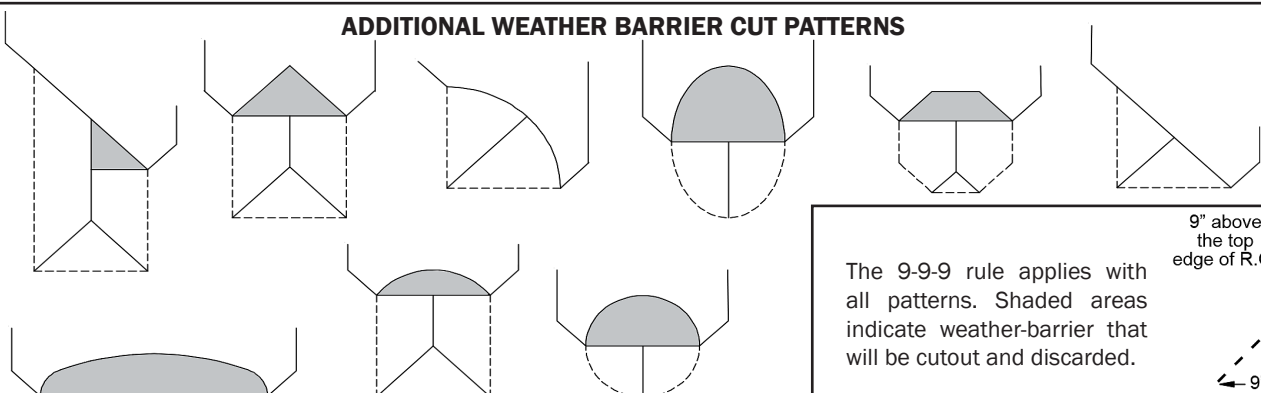
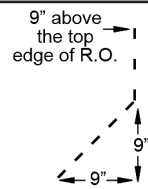

Figure 4

## ADDITIONAL WEATHER BARRIER CUT PATTERNS



The 9-9-9 rule applies with all patterns. Shaded areas indicate weather-barrier that will be cutout and discarded.



## Window Installation

Before installation check window to make sure unit is complete and without defects.

**SHIMMING:** Sill shims are to be applied at each jamb and any mulls on multiple wide units. Units wider than 24" must also be shimmed at the center of the sill (fig. 5)

Corner gussets are supplied for use with all aluminum clad windows. Note: The WV line has an integral continuous nail fin, which eliminates the need for corner gussets.

Place the corner gussets at the nailing fin corners. After corner gussets are in place, use sealant on any gap that may exist between the gusset and unit to make a weather tight seal. Do not install unit if corner gussets are missing. Contact your Lincoln dealer for replacements.

Apply a continuous bead of sealant, approximately 3/8" in diameter, to the back of the mounting flange and in line with the mounting holes. Alternatively, sealant can also be applied to the R.O. to line up with the holes on the mounting flange (fig. 5).

Place window into opening, press tight to building and check for square, level, and plumb (fig. 6).

At left or right-side corner, tack window through one mounting hole. This will provide you with the ability to adjust the unit while keeping the window in place (fig. 6). Lincoln Wood Products Inc. recommends the use of fasteners that penetrate window framing a minimum of 1". Stainless or galvanized nails or screws may be used. However, Lincoln Wood Products Inc. does not recommend the use of pneumatic nail guns and will not be responsible for any damaged caused by the use of these nail guns.

Check unit for square and plumb, making adjustments using shims until window is square and plumb in the opening. **NOTE:** Unit must be installed square, plumb and level or warranty may be void.

Tack opposite diagonal corner from first tack and check for level, plumb, and square.

Fasten sides, top, and bottom, using every other mounting hole and continually checking unit for square, plumb, and level.

**Jamb Flashing:** The flashing can be flexible or adhesive back flexible. All flashing must be at least 9" wide and cut so length will extend 8-1/2" beyond the head and sill on both sides of R.O. (R.O. + 17"). If stapling flashing do not penetrate through window mounting flange.

Apply a continuous vertical bead of sealant to the exterior portion of the vertical mounting flange, covering the mounting holes as you go. Continue bead 8-1/2" above the R.O. (fig. 7).

Install jamb flashing over side mounting flange and sealant bead, tight against window unit. Top edge of jamb flashing should extend a maximum of 8-1/2" above the R.O. The bottom of the jamb flashing extends 8-1/2" past the bottom of the R.O. overlapping the sill flashing applied earlier (fig. 7).

**Diagonal Flashing:** The flashing can be flexible or adhesive back flexible. All flashing must be at least 9" wide, and diagonal flashing must be cut so the length overlaps the jamb flashing. Diagonal flashing must also be long enough that it can be covered by the head flashing. If stapling flashing do not penetrate through window mounting flange.

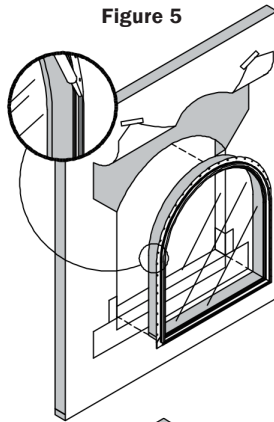

Figure 5

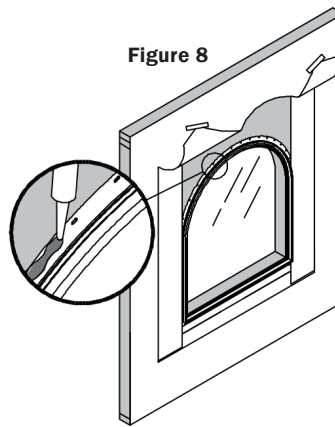

Figure 8

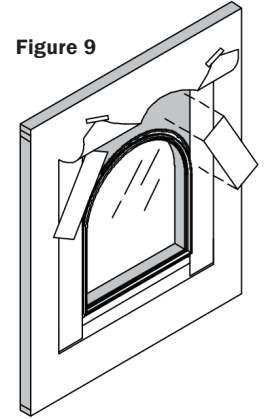

Figure 9

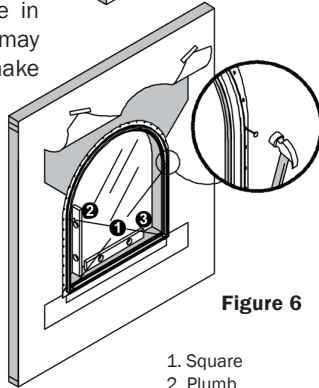

Figure 6

1. Square
2. Plumb
3. Level

Apply a continuous bead of sealant to the exterior portion of the curved mounting flange, covering the mounting holes as you go (fig 8).

Install diagonal flashing in weather-board fashion (fig.9). Additional diagonal flashing should be applied above and lapped over the previous layer, from the bottom up (fig. 10).

**Head Flashing:** The flashing can be flexible or adhesive back flexible. All flashing must be a minimum of 9" wide and cut so length is approximately 10" beyond the sides of the R.O. (R.O. + 20"). This will allow the head flashing to overlap the jamb and diagonal flashing applied earlier.

Install head flashing over the horizontal mounting flange and fasten. If using a non-adhesive flashing staple, being sure not to penetrate through window mounting flange (fig. 11).

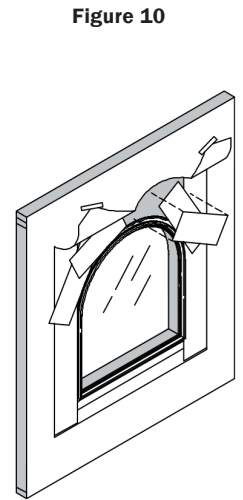

Figure 10

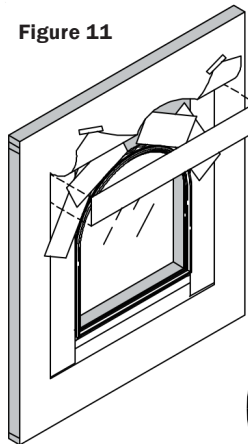

Figure 11

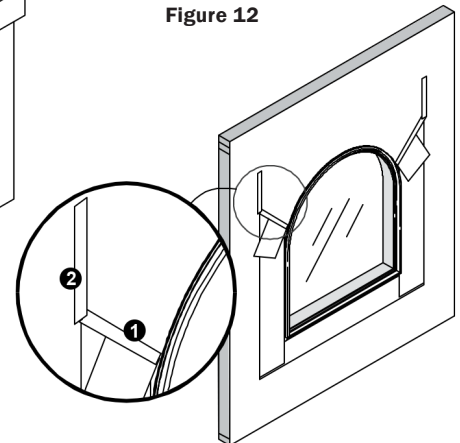

Figure 12

Lower the head weather barrier flap, previously taped out of way (fig.12), over the head flashing.

Use sheathing tape to seal the cuts made in the weather barrier when the flap was made. The diagonal cut should be taped first ① and then overlapped by a second strip ② which will cover the vertical cut. Repeat this procedure on the opposite side of the window (fig. 12).

### This completes your window installation.

Failure to follow these recommended instructions may void Lincoln's Limited Warranty